

Fast and slow light in linear atomic media

Will Brown, Michael Vanner, Russell McLean, Andrei Sidorov,
Peter Hannaford and Alexander Akulshin

*ARC Centre of Excellence for Quantum-Atom Optics,
Centre for Atom Optics and Ultrafast Spectroscopy,
Swinburne University of Technology, Melbourne*



AUSTRALIAN RESEARCH COUNCIL
CENTRE OF EXCELLENCE FOR
QUANTUM-ATOM OPTICS



Motivation and Aims

- Tunable delay of optical signals:
 - pulse train synchronization,
 - data packet buffering.
- Delay of non-classical states in quantum information processing.
- Simple schemes for delay and advance: intrinsic dispersion associated with atomic transitions.
- For practical delay lines:
 - large bandwidth ~GHz,
 - delay-bandwidth product $\delta\Delta\nu = \delta/\tau > 1$
 - tunable delay
 - minimal pulse distortion.

Slow and fast light

• **Phase velocity:**

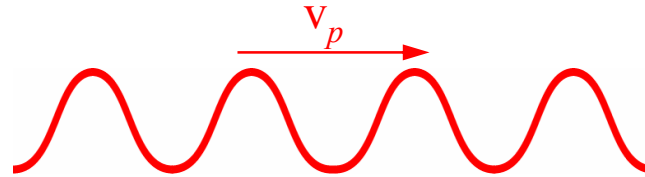

$$v_p = \frac{c}{n(\nu)}$$

with dispersion $dn/d\nu$, spectral components of a pulse “rephase”, pulse travels at **group velocity** v_g

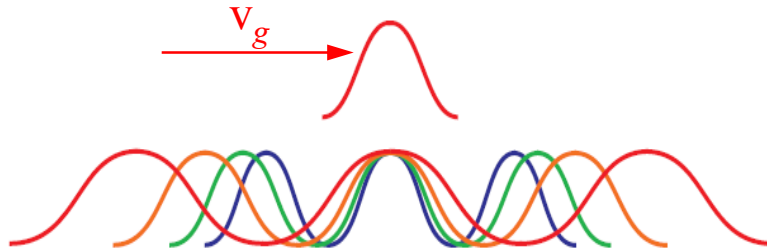

$$v_g = \frac{c}{n(\nu_0) + \nu_0 \frac{dn}{d\nu}}$$

Positive (normal) dispersion: $\frac{dn}{d\nu} > 0$ $v_g < c$

Negative (anomalous) dispersion: $\frac{dn}{d\nu} < 0$ $v_g > c$ or $v_g < 0$

Slow light in *coherent* atomic media

Electromagnetically induced transparency
(transitions with $F_g > F_e$)

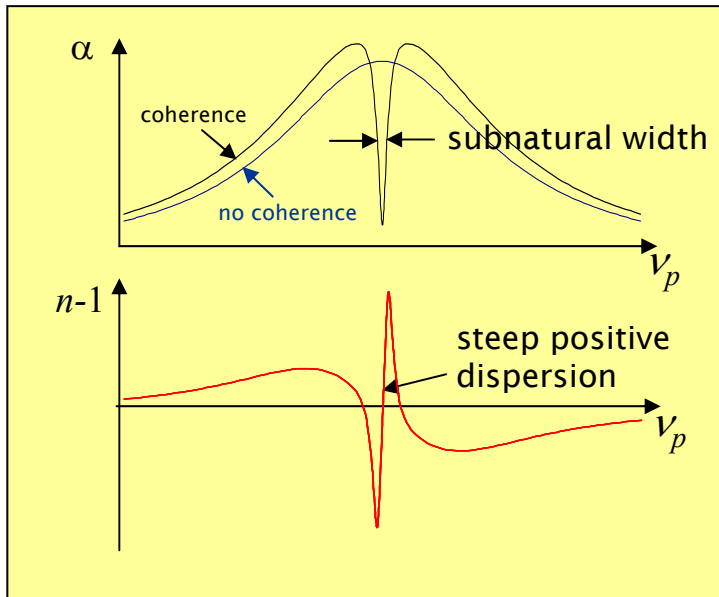
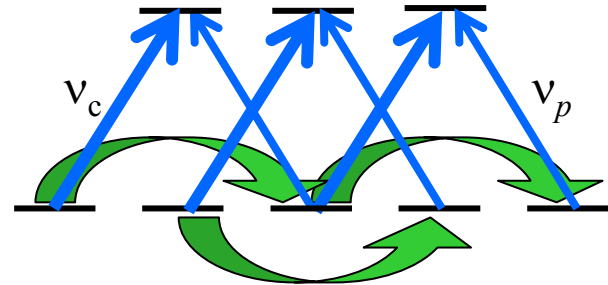

Narrow bandwidth of EIT resonance:
 $\Delta\nu < 1 \text{ MHz} \Rightarrow$ pulse length $\tau > 1 \mu\text{s}$

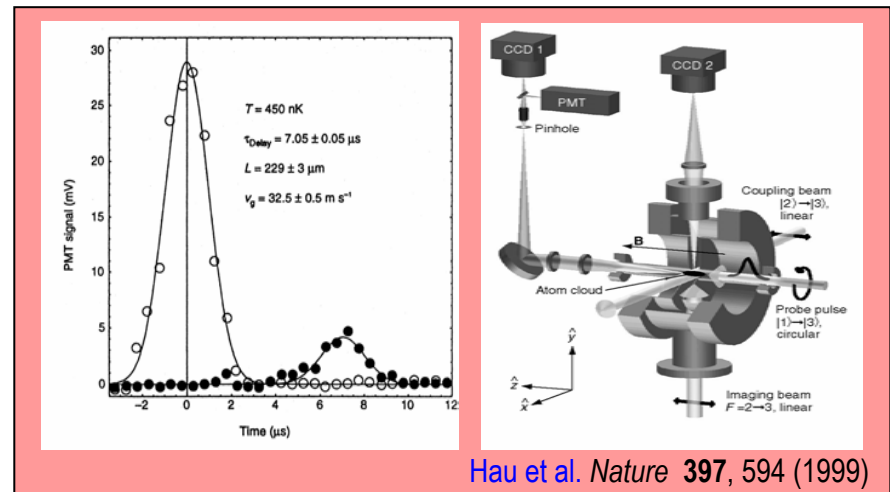

Hau et al. *Nature* 397, 594 (1999)

Other slow light techniques, e.g. gain lines in optical fibre:

Raman amplification (Sharping et al *Opt Exp* 2005)

Brillouin scattering (Okawachi et al. *PRL* 2005)

Positive dispersion between pairs of absorption lines

Slow light in region of intrinsic positive dispersion between two widely spaced absorption lines.

Camacho et al. *PRA* 73, 063812 (2006)

Camacho et al. *PRL* 98, 043902 (2007)

Rb D₂ transmission profile (780nm)

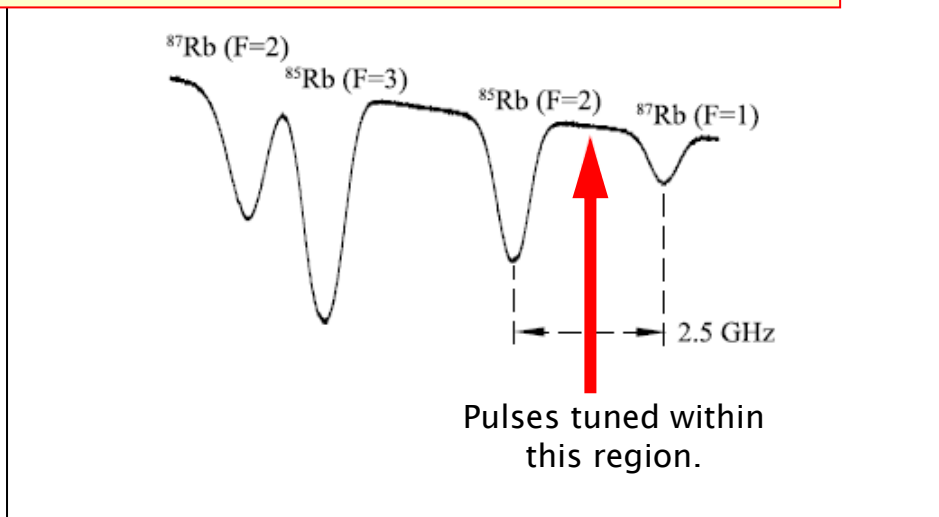

- Dispersion \ll EIT-based dispersion
- Large bandwidth \sim GHz \Rightarrow pulse width \sim ns.
- Linear dispersion and flat absorption
 - expect good pulse preservation

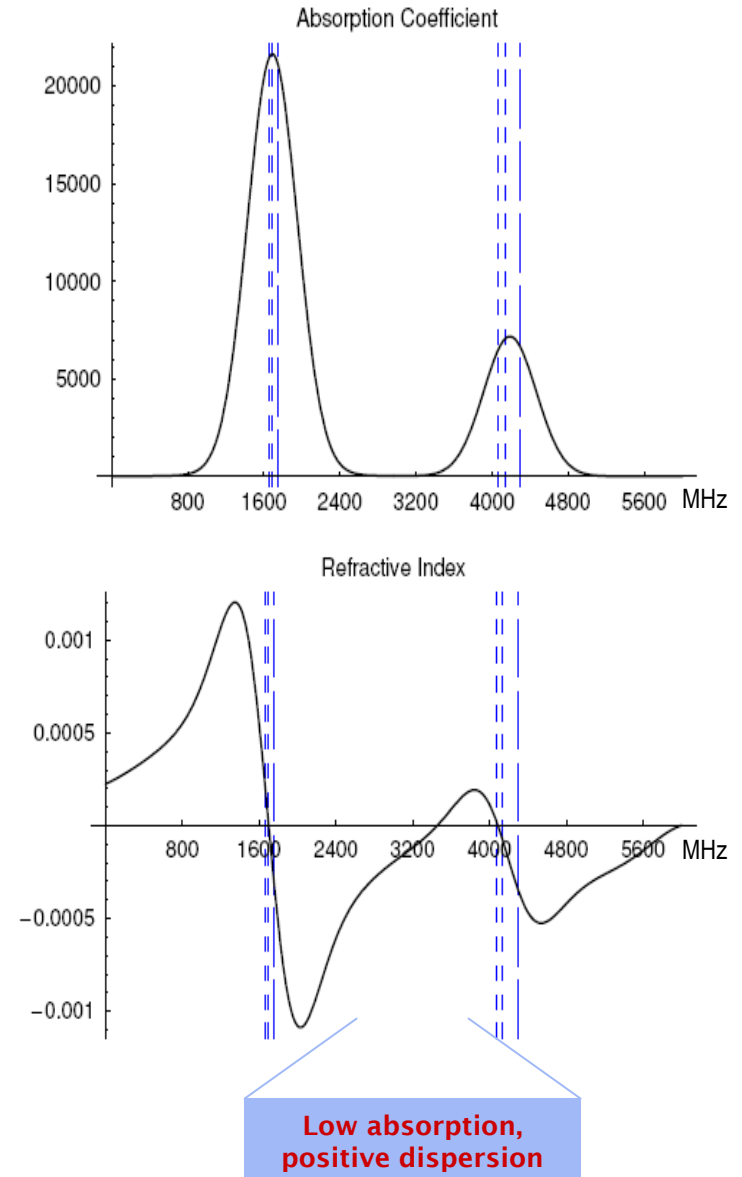

Experimental setup for observing delayed pulses

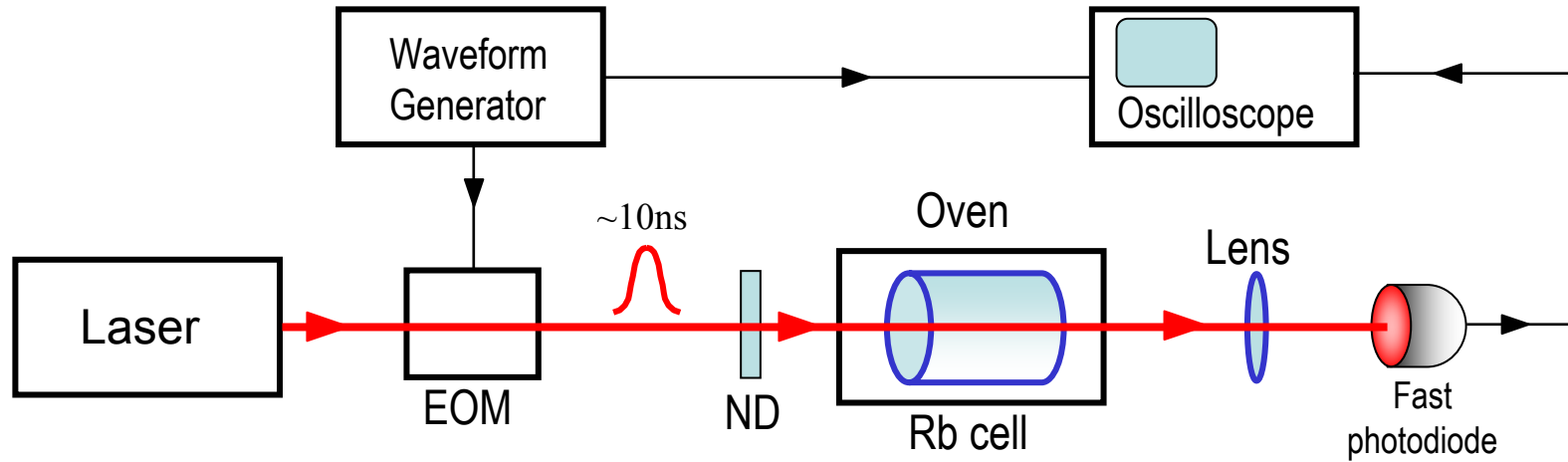

All-optical delay between $^{85}\text{Rb}(F=2)$ and $^{87}\text{Rb}(F=1)$ components

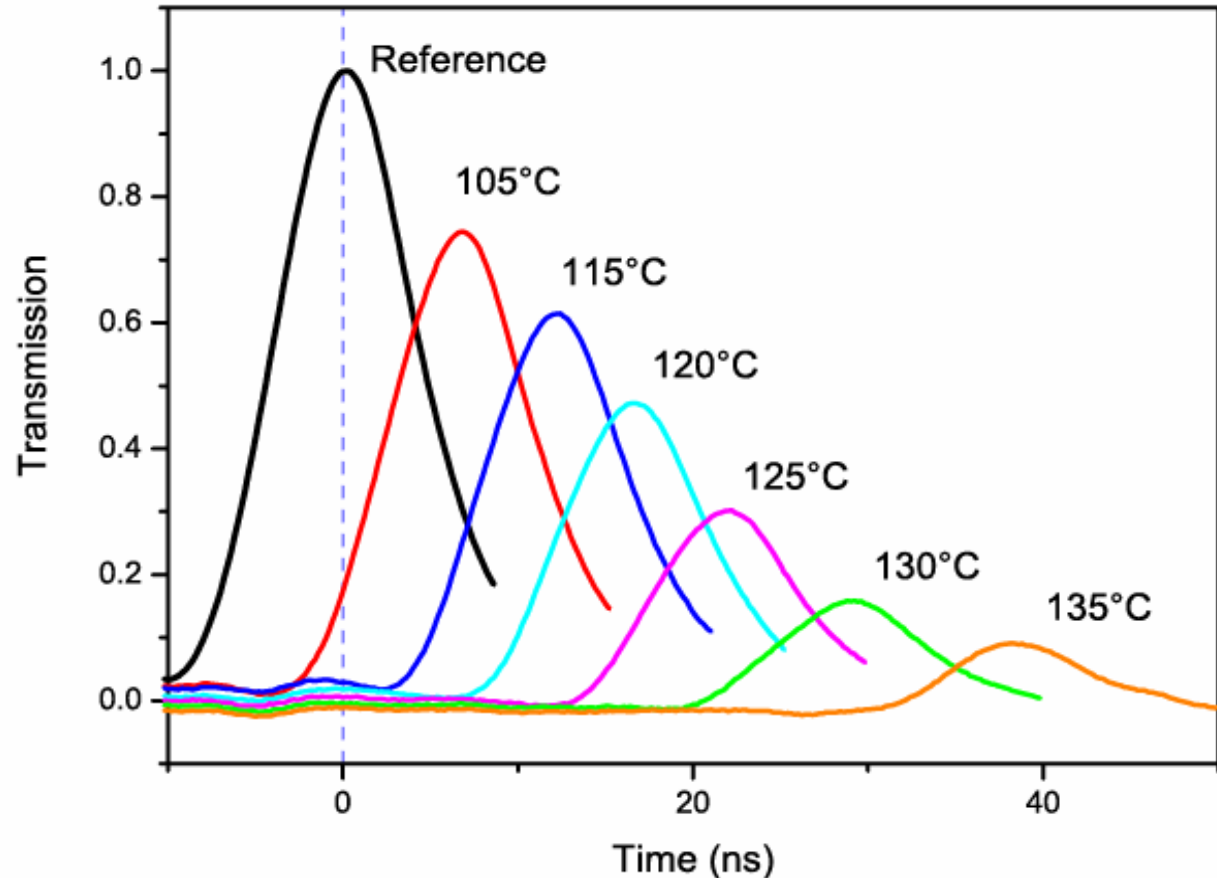
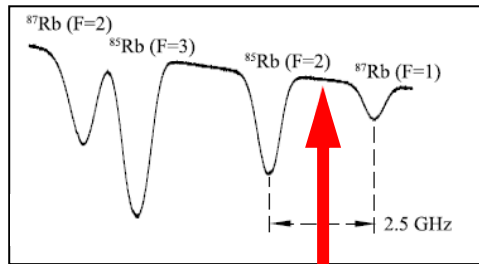

- Increasing T increased number density, absorption, dispersion
- Trade-off between delay and transmission.
- **Fractional delay $\delta/\tau \sim 4.3$ for 10% transmission**
(limited by pulse length from EOM)
- Good pulse shape preservation

Frequency dependence of transmission and delay

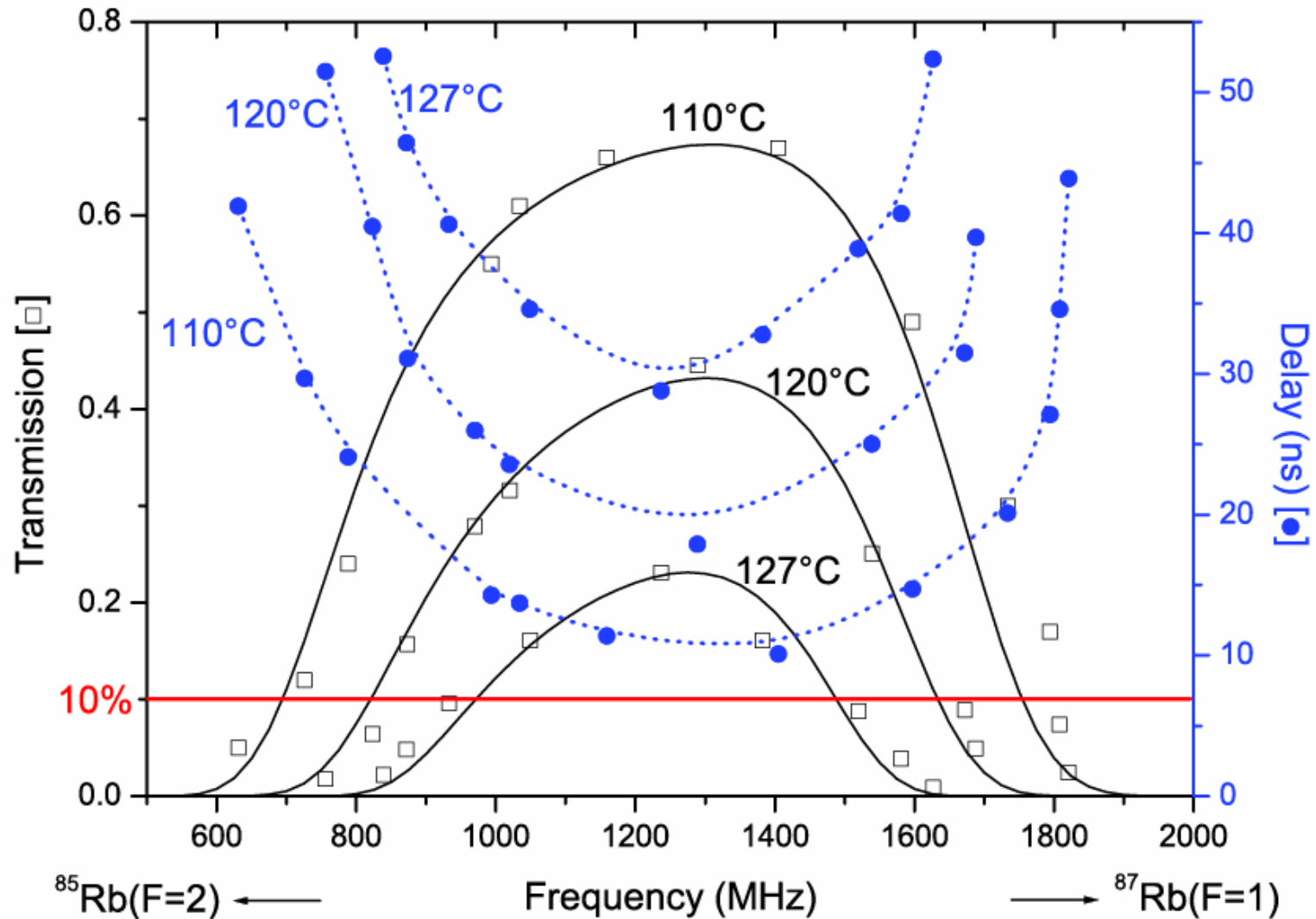

Coarse but slow control of delay via temperature tuning.

Experimental setup for rapid control of delay

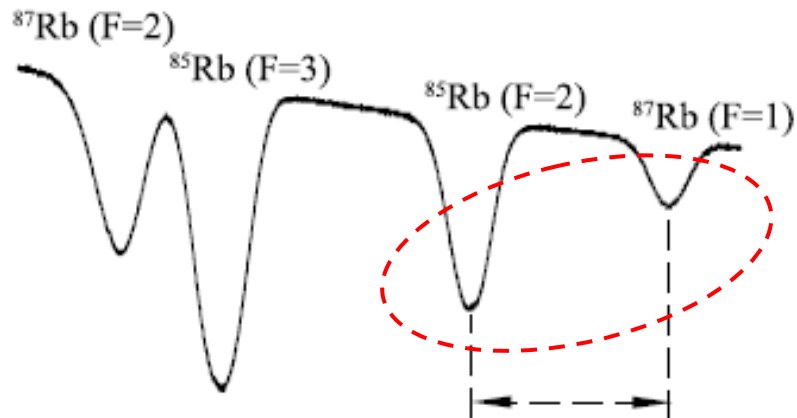
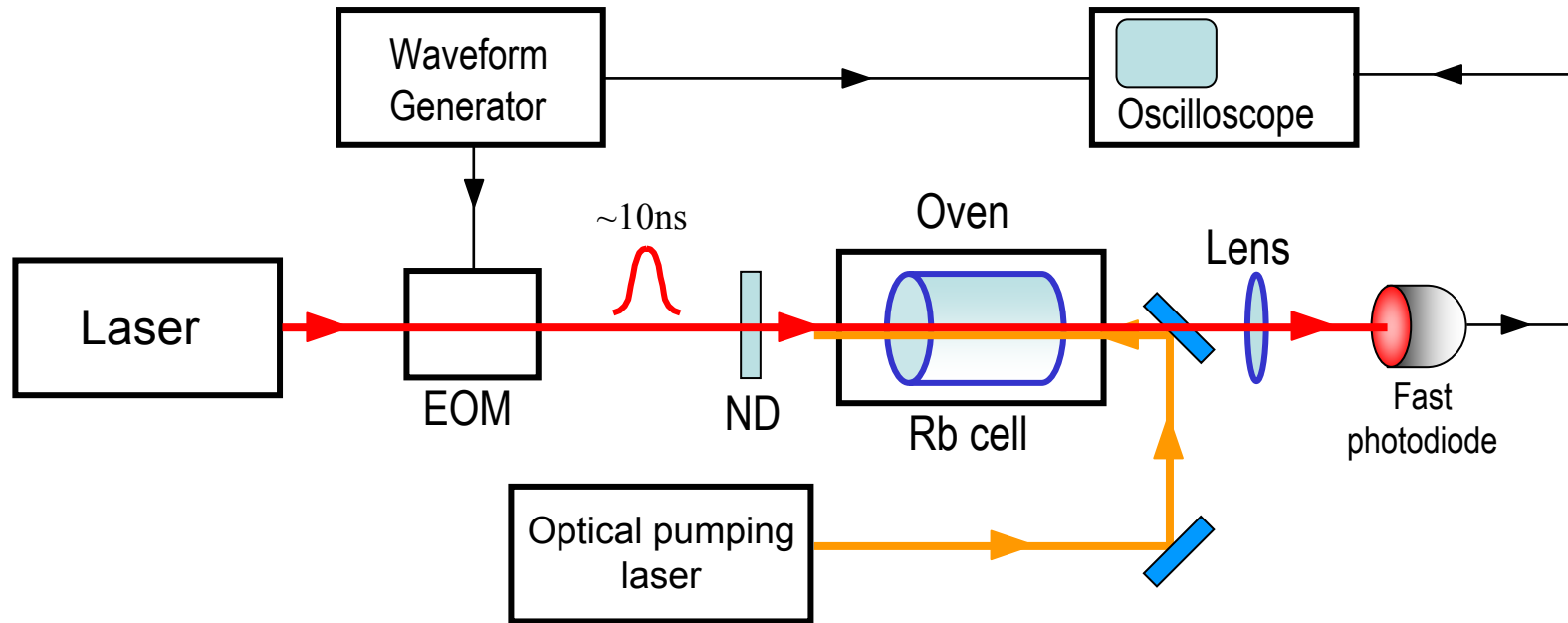

- Optical pumping on ^{87}Rb D1 line modifies ^{87}Rb ground state hyperfine populations.
- Increase or decrease ratio of ^{85}Rb (F=2) and ^{87}Rb (F=1) absorption peaks, and dispersion between them

Tunable Delay with Optical Pumping

Effect of optical pumping on ^{87}Rb D_1 line (795 nm):

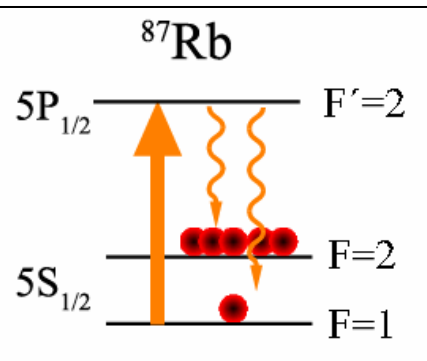
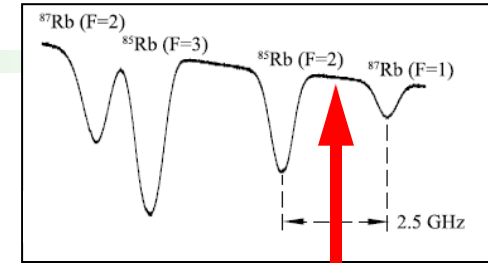

~15% less delay
(F=1 popn reduced)

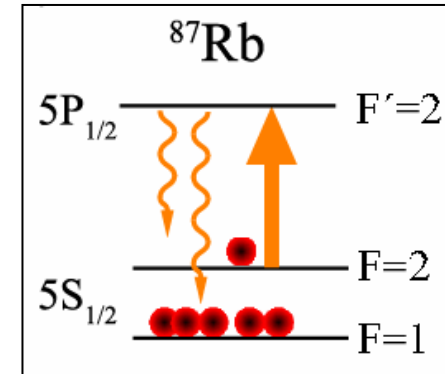
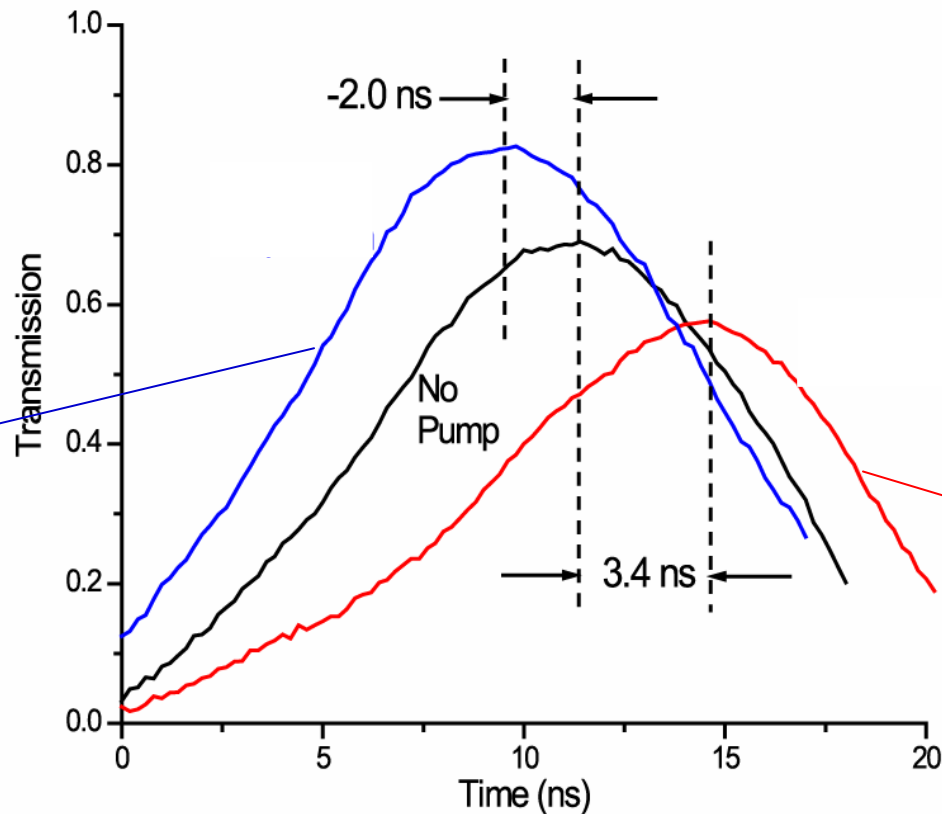

~25% more delay
(F=1 popn increased)

Fast light in coherent atomic media

Electromagnetically induced absorption

$$0 < F_g < F_e$$

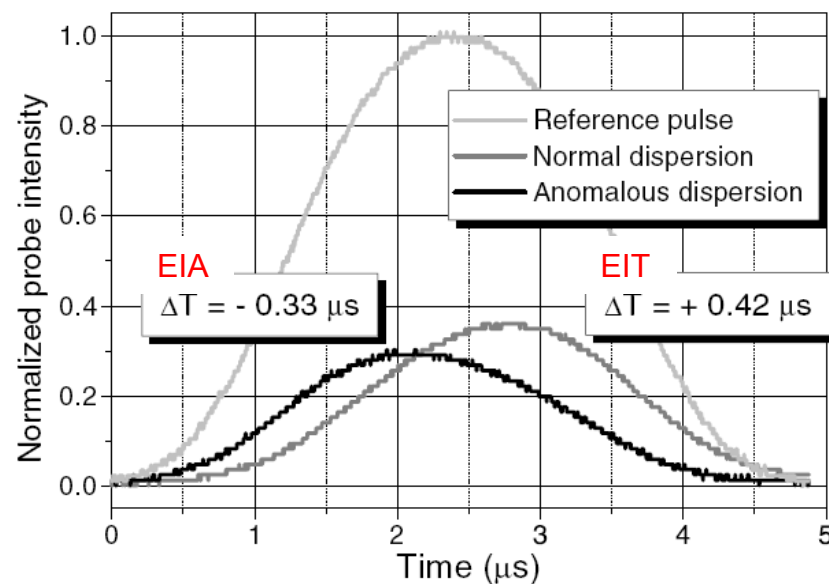
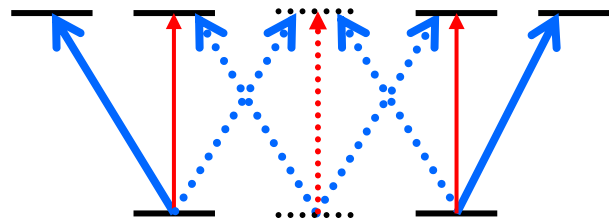
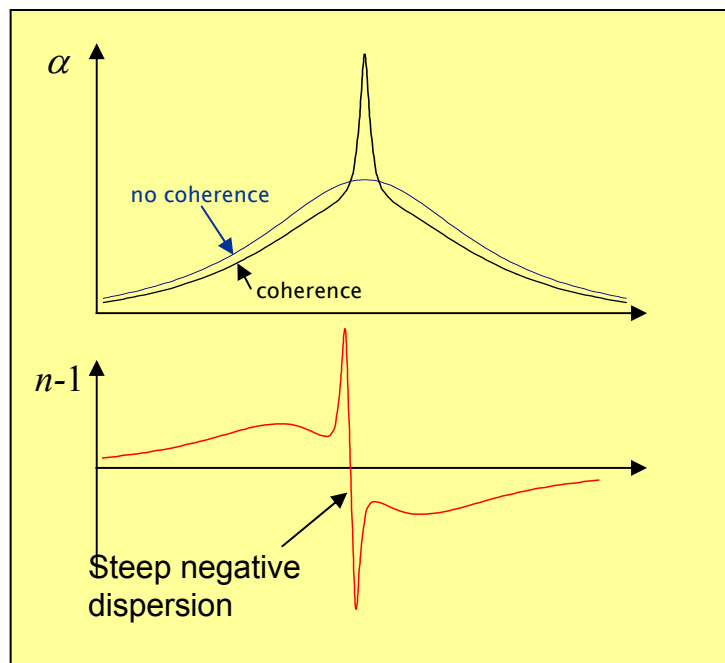

Akulshin *et al* *J Opt B* **5** S479 (2003)

Other techniques for generating anomalous dispersion in atomic media

- Raman gain doublets (Wang *et al Nature* **406** 277 2000)

Ongoing debate about the nature of superluminal propagation – aim to use a simple system

Fast light in linear atomic medium

Dispersion at atomic resonance depends on the linewidth γ : $\left. \frac{dn}{d\nu} \right|_{\nu_0} = \frac{\alpha(\nu_0)}{k_0 \gamma}$

Absorption resonance can have very steep associated dispersion if it is sufficiently narrow.

Reduce Doppler width, increase dispersion by using MOT.

No subnatural width coherences.

Characterisation: RF heterodyne technique to measure dispersion

Dispersion measured via phase shift of signal wave at ν of $\Delta\phi = 2\pi\nu L(n-1)/c$

Reference beam at $(\nu-80 \text{ MHz})$ off resonance – no phase shift.

$\Delta\phi$ detected on RF beat signal

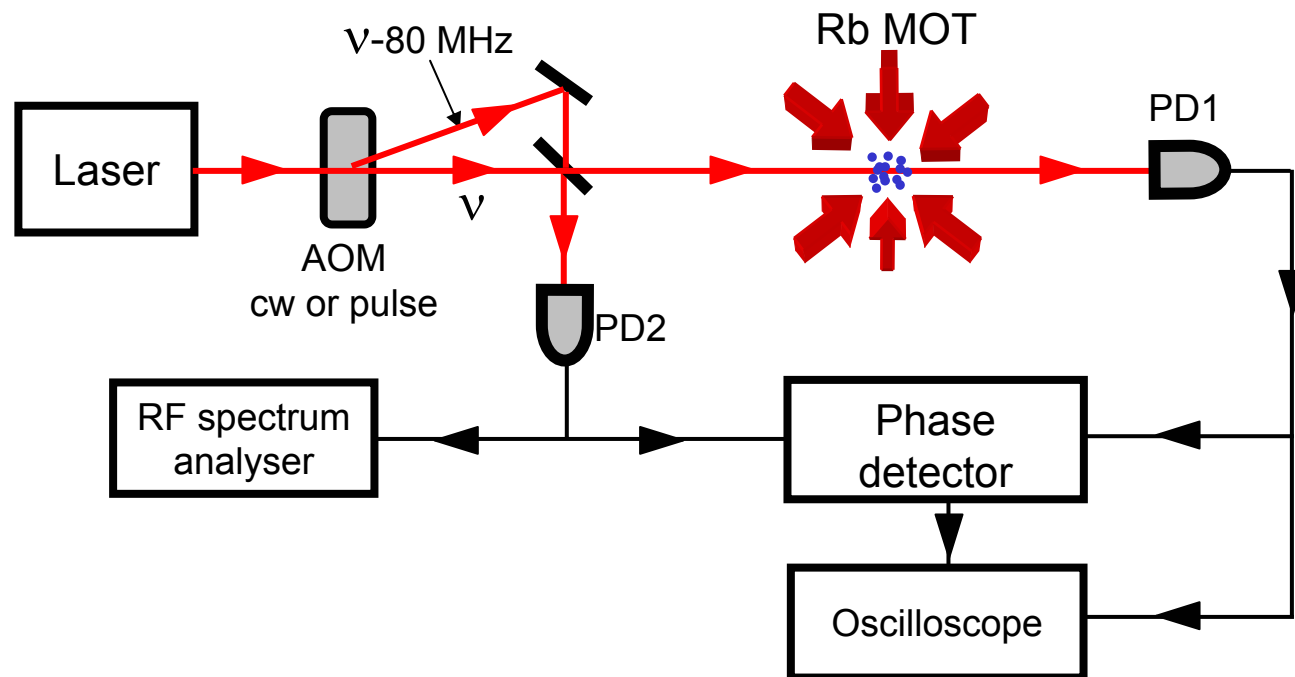

RF heterodyne technique insensitive to acoustic noise.

PD2 senses signal and reference optical components before MOT, = RF reference for the phase detector

Characterisation: transmission and phase profiles

(Offset between probe and control beams 80 MHz)

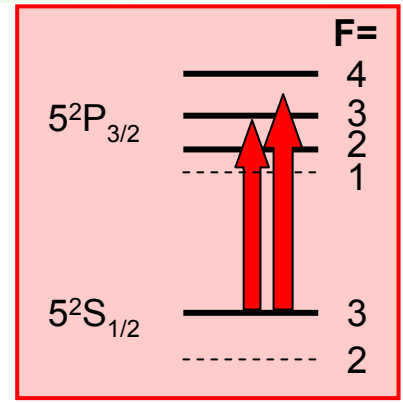
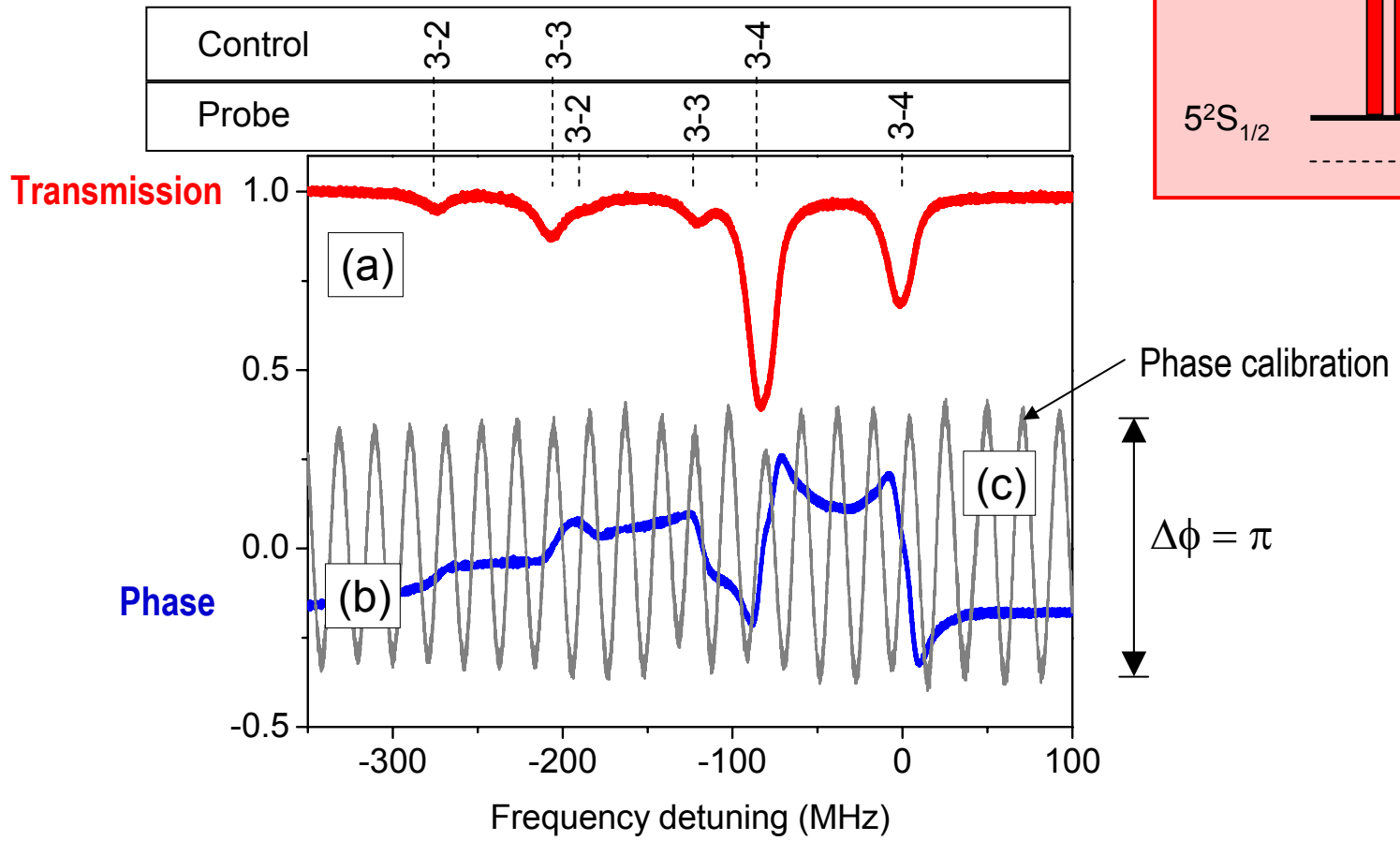

Characterisation: transmission and refractive index profiles

(Frequency offset 220 MHz)

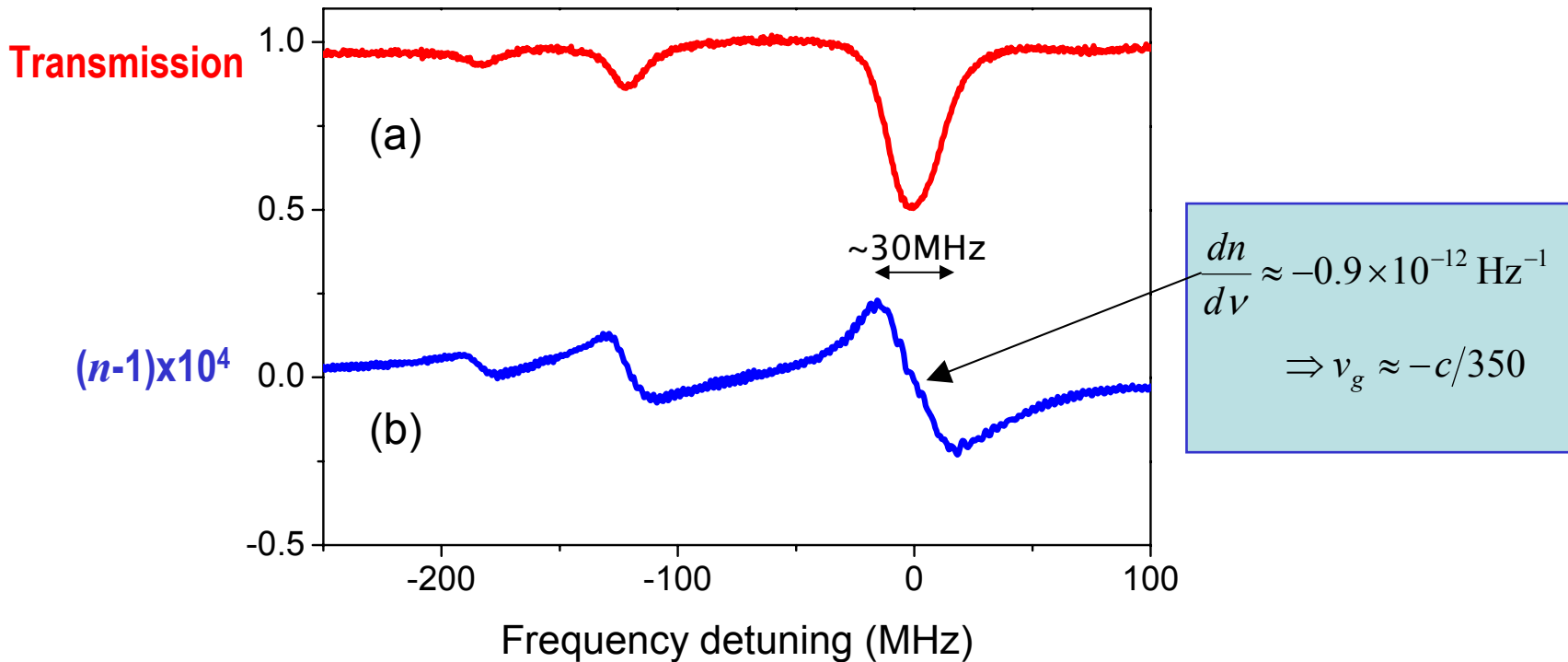

Observing the pulse advance

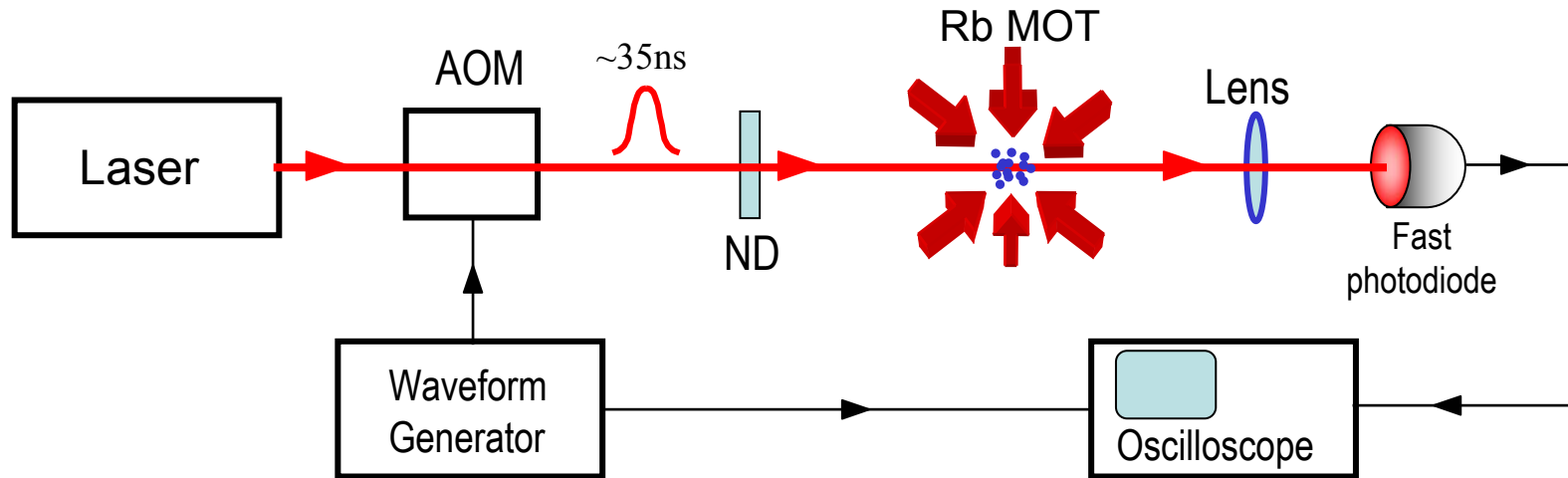

Pulse advance in MOT

Probe on $^{85}\text{Rb } 5^2\text{S}_{1/2} (F=3) \rightarrow 5^2\text{P}_{3/2} (F'=4)$

Resonant pulse normalised to control pulse.

Attenuation of resonant pulse < 50%.

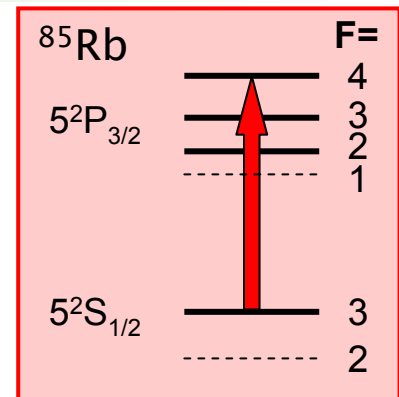
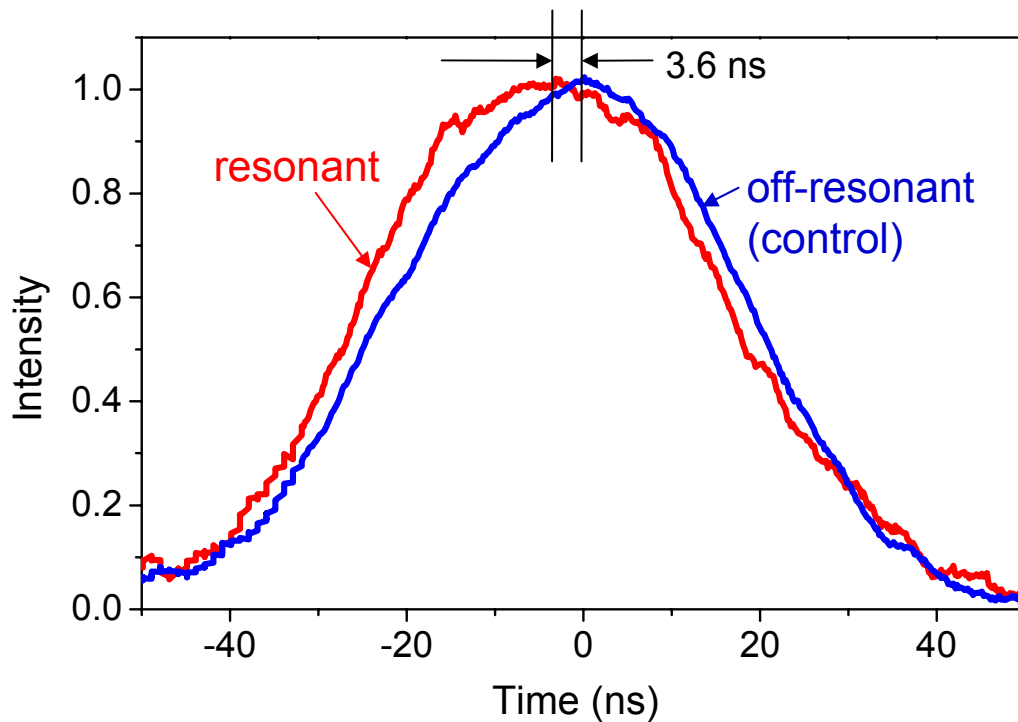

Advance $\Delta T \approx 3.6 \text{ ns}$

$$\Rightarrow v_g \approx -c/360$$

Fractional advance $\sim 10\%$

- More difficult to achieve large fractional advance than delay

Summary

- Both pulse **delay** and **advance** observed in regions of linear atomic dispersion
- **Fractional pulse delays > 4.3** (limited by pulse length) with transmission $\approx 10\%$ and minimal pulse distortion
- **Fast tuning** of delay via redistribution of population by **optical pumping**
- Pulse advance in linear dispersion through Rb MOT
 - (≈ 3.6 ns; 10% fractional advance; $v_g = c/360$)