

Analysis of Bubble Flow in Metallurgical Vessels

Mid Term Report

Xiaodong Bernard Xu

Faculty of Engineering and Industrial Sciences

Commenced Ph D in February 2007

Supervisors: **Prof. Brooks** (SUT)

Dr. William Yang (CSIRO)

Dr. Ali Bab-Hadiashar (SUT)

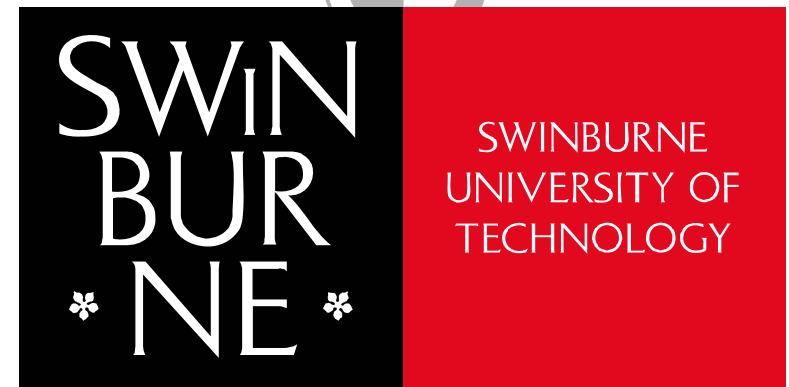

Content Outline

1. Introduction
2. Progress
 - Literature review, on bubble fundamentals, image and acoustic analysis, multivariate statistical analysis (Draft submitted Feb 18 2008)
 - Cold modelling experiments (commenced)
 - Image and acoustic analysis techniques established
 - Industrial trials (commenced)
 - Presentations, Paper and Report
3. Plan for the next stage

1. Introduction

Behaviour of bubbles are related to crucial aspects of metallurgical operations.

Development of sensors may lead to improve understanding and control of the process.



Images from Prof. Brooks

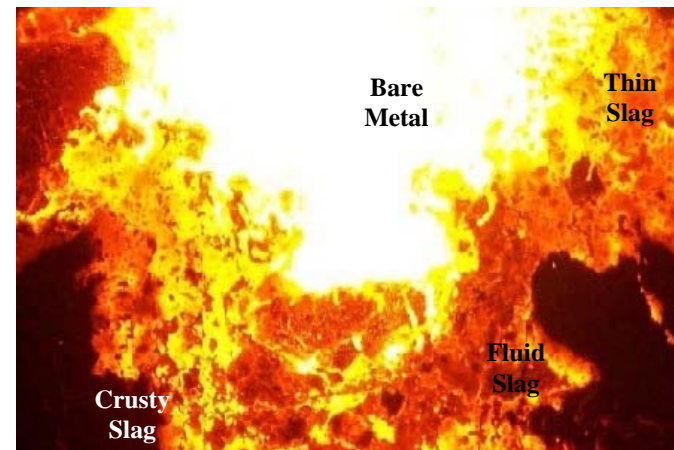

Image of ladle "eye"

Bubbling in cold models provide visual and acoustic data for verifications of mathematical models

Rapid image analysis using multivariate statistics has been developed.

Acoustic signal?

- Simultaneous?
- Online ?
- Complex system?

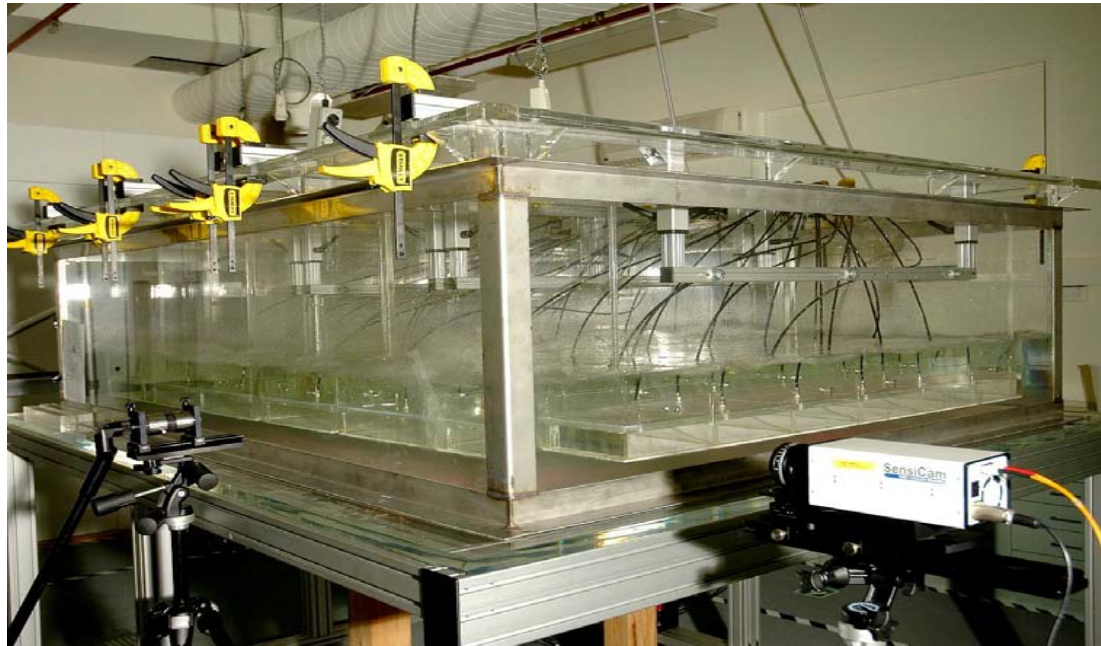

Aims of the Project

1. Develop mathematical techniques to provide rapid analysis of bubbling flow in cold models of metallurgical processes.
2. Develop techniques for simultaneous analysis of acoustic and image data generated from bubbling flow in cold models.
3. Apply these techniques to cold models of AI cells.
4. Evaluate the use of these techniques in industrial system.

Literature Review

Bubble fundamentals and recent research

Image analysis

Acoustic analysis

MV analysis

Ladle eye phenomena

Review of Bubble Behaviour

Definition: gas surrounded by a bilayer of surfactant in a second gas phase, gas surrounded entirely by a liquid.

Size: cm- μ m,

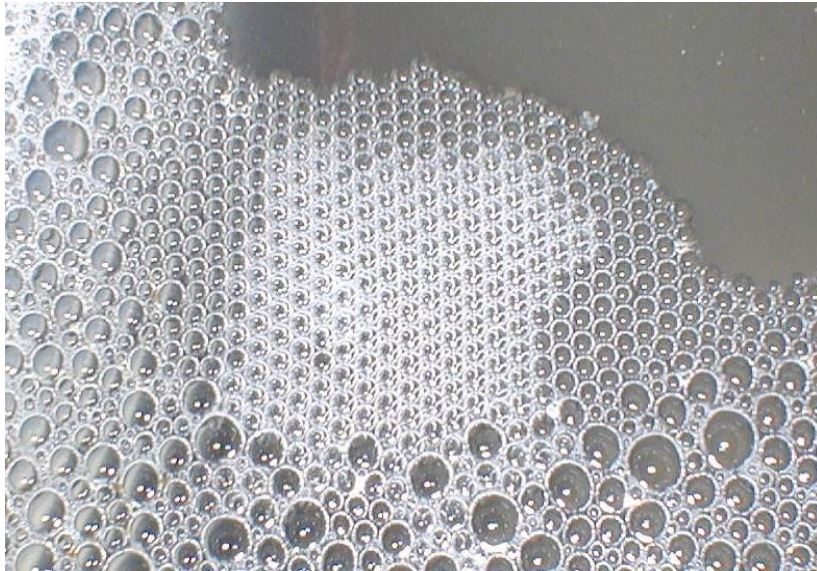

Image from wikipedia



From: <http://www.bubbleart.com>

Formation: $\Delta G_{total} = 4\pi r^2 \gamma - \frac{4}{3}\pi r^3 \Delta G_V$

Spontaneous bubble formation

homogeneous & heterogeneous nucleation

cavitation, electrolysis

Non-Spontaneous bubble formation

Sparging, Entrainment, Attrition

Growth of bubbles

Detachment of bubbles

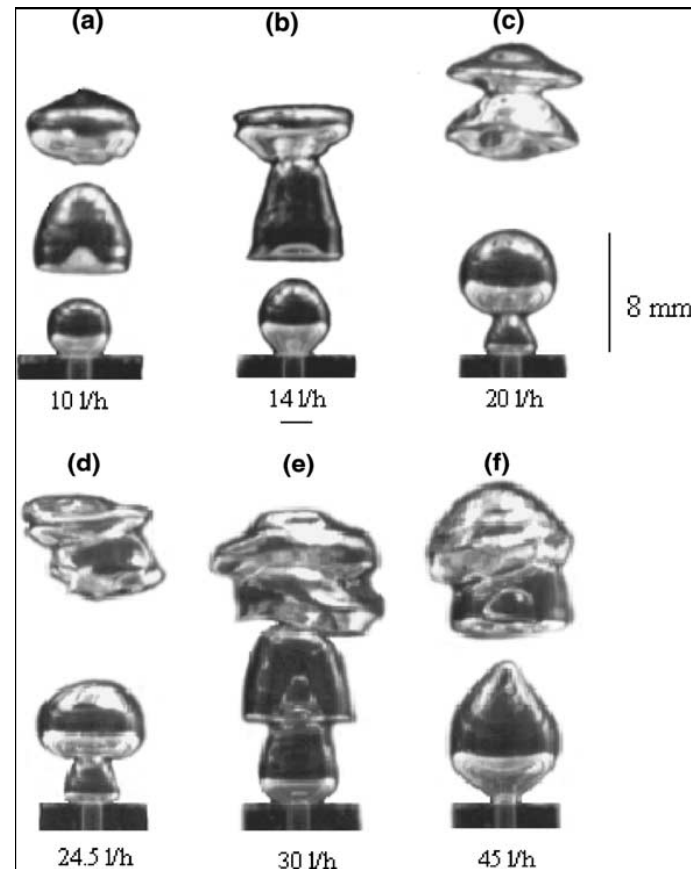

Bubble Investigation Equipment

Investigation of bubble formation and sizing in laboratory experiments relies on high speed photography, application of an electrical triple probe or novel video techniques.

- ❖ Laser techniques
- ❖ Holography
- ❖ Phase-Doppler method
- ❖ Tomography
- ❖ Schlieren technique
- ❖ Particle image velocimetry technique

R. Manasseh, "Passive acoustic bubble sizing in sparged system", Experiments in Fluids Vol. 30 (2001), pp 672-682,
Investigated bubbles formed at higher air flow rate.
Acoustic frequency by bubbles (2-4 mm) varied during pulse.

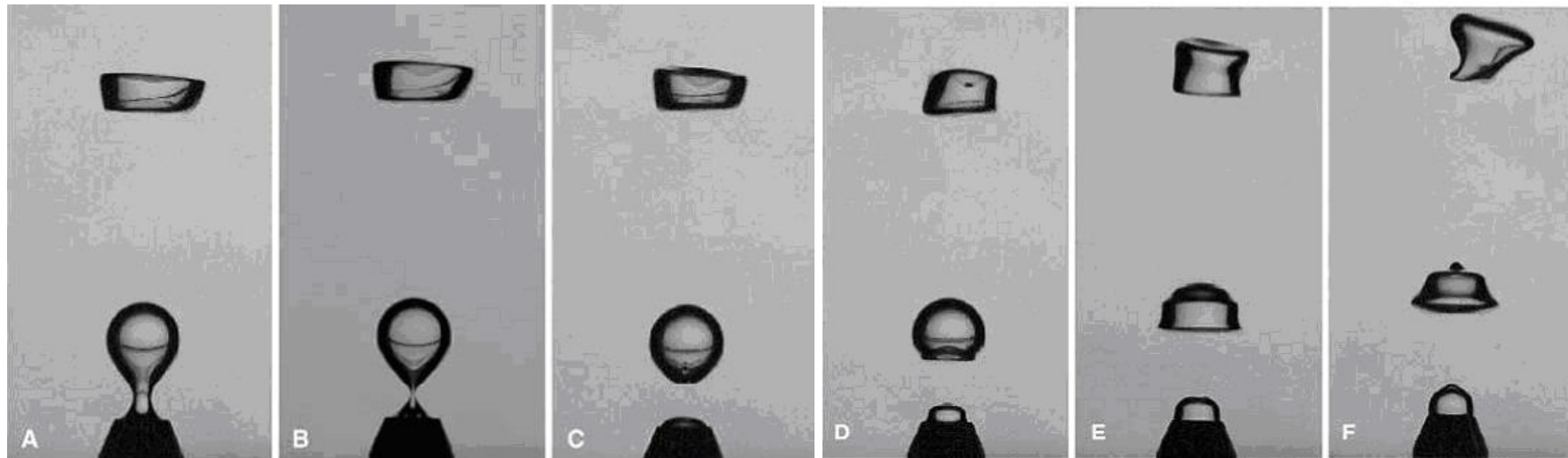

Research in Bubbling Phenomenon

Iguchi, et al, ISIJ
international, Vol. 31
(1991), No. 9, pp
952-959

Investigated of
bubbles in a vertical
cylindrical vessel.

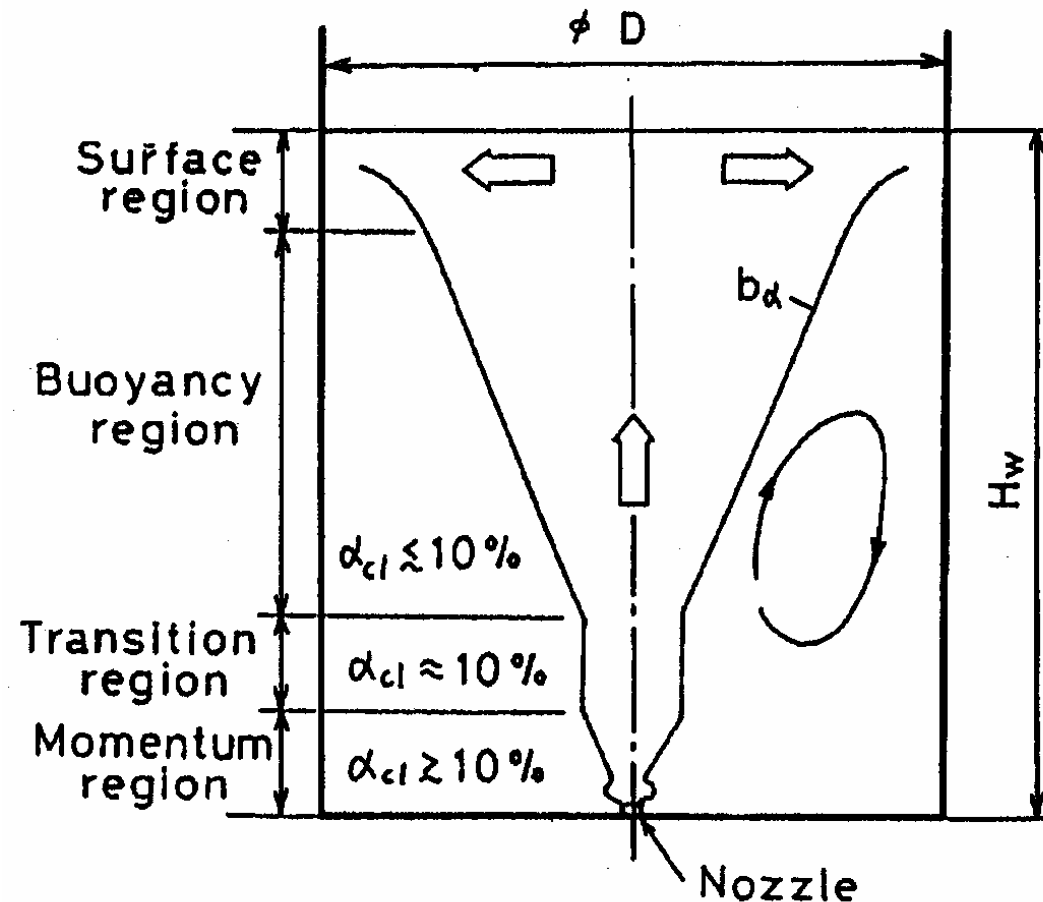

- Flow in momentum region mainly governed by inertia force,
- Buoyancy force plays important role in buoyancy region,
- Value of bubble frequency 20 to 30 Hz,
- Bubble diameter estimated to be 1.3 to 1.6 cm, when the air flow rate was set at $41.4 \text{ cm}^3/\text{s}$ (2.484l/min).

- Flow rate larger than 10 l/min, ...

Krishnapisharody and
Irons, Met Mat
Trans; Vol.
37B(2006), 763-772

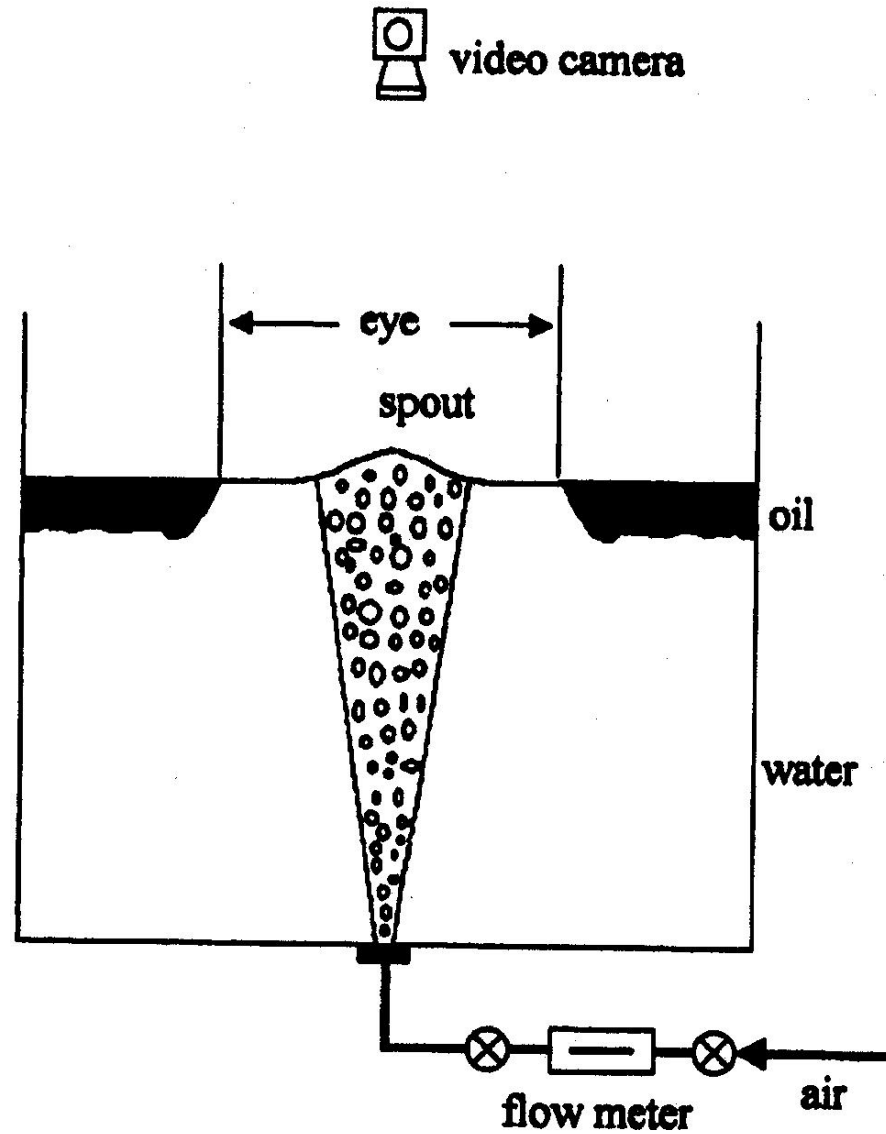

- o Size of the eye increase with gas flow rate and decreases as upper phase thickness increase.
- o Eye size increases with increasing lower phase depth.
- o Density ratio of the upper and the lower phases affects the eye size; relatively, less dense upper phases have small eye sizes.

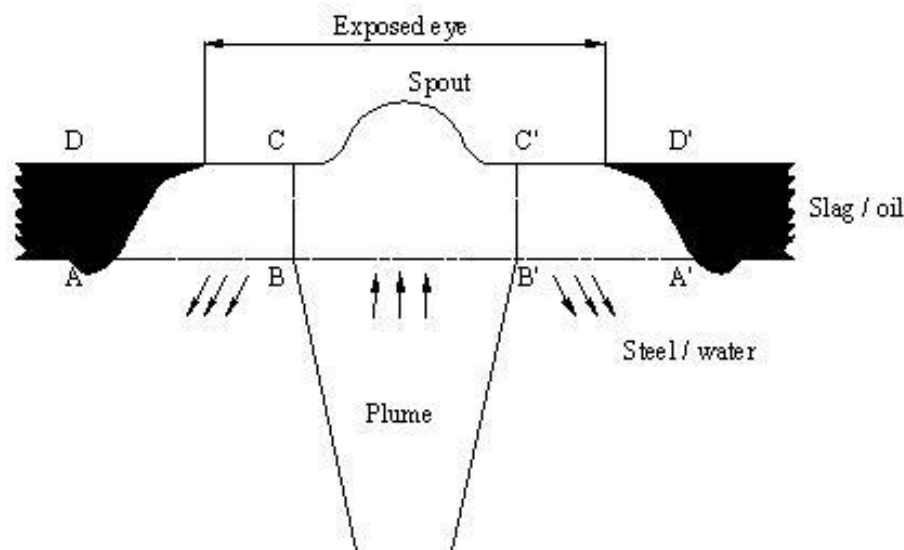

Krishnapisharody and Irons (2006)

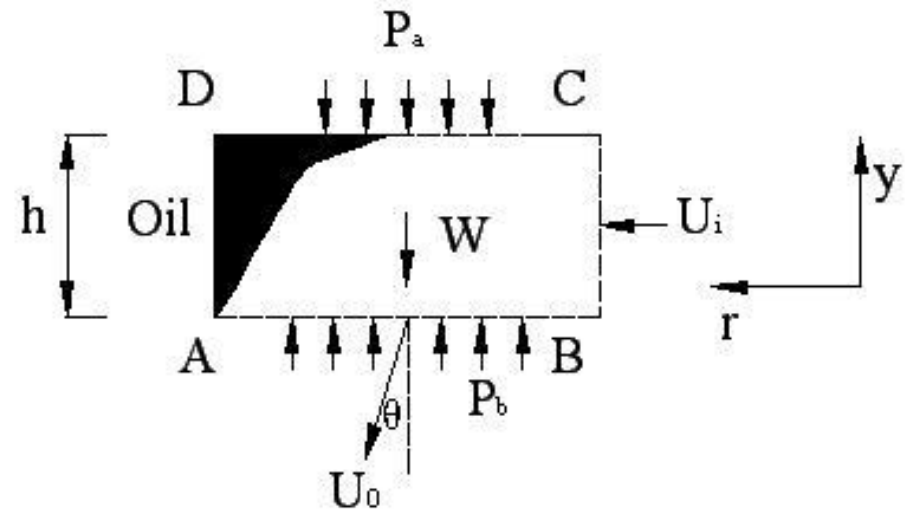

Krishnapisharody and Irons (2006)

The following equation was deduced according to the pressure balance and the momentum balance:

$$A^* = \frac{A_e}{H^2} = \alpha + \beta \left(\frac{\rho}{\Delta\rho} \right)^{1/2} \left(\frac{U_P^2}{gh} \right)^{1/2}$$

However, the following factors have not been considered:

- ❖ Transient behaviour
- ❖ Wake effect of previous bubbles
- ❖ Interactions with the container

Review of Image Analysis

Image digitalization (sampling, quantization, etc.)

Binary image, gray or colour (RGB)

The manipulation of image analysis can be divided into three categories:

- **Image Processing** image in -> image out
- **Image Analysis** image in -> measurements out
- **Image Understanding** image in -> high-level description out

Types of operations:

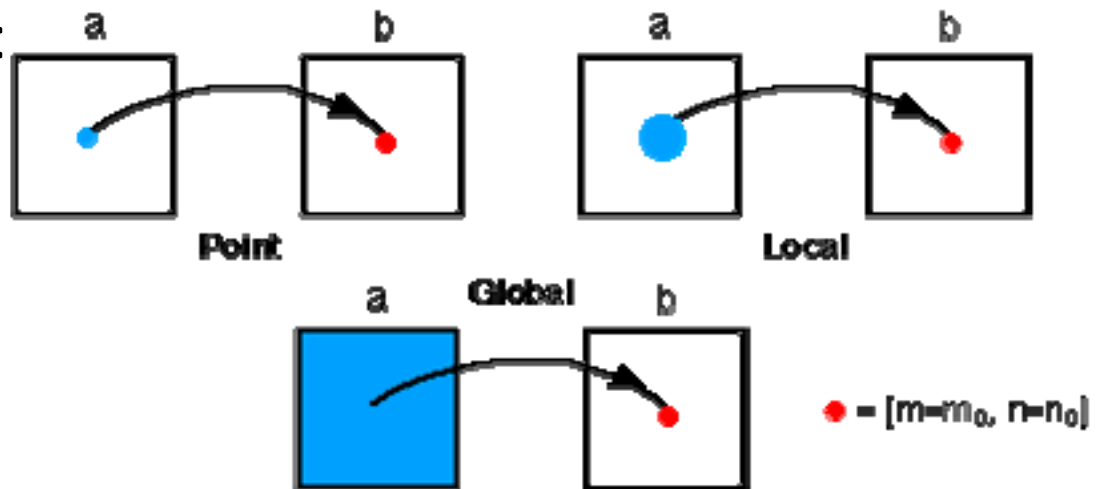



Mean Filter & Histogram of the Mean Filter

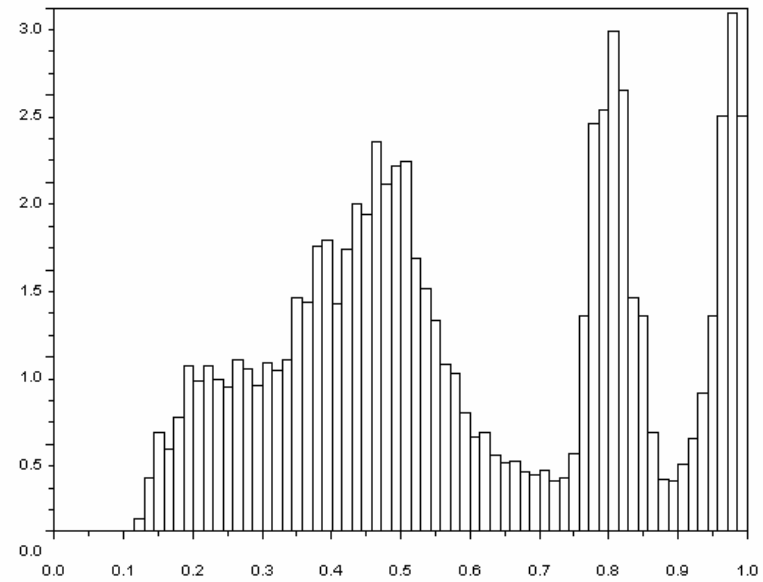

Laplace Filtering & Filter Histogram

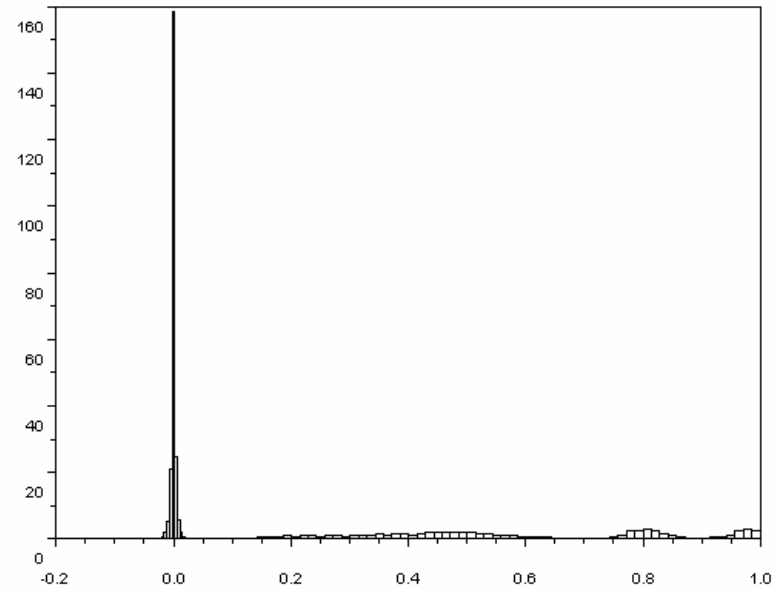

Review of Acoustic Analysis

Sounds are pressure waves of air, and is created by vibrations

Digitalization:

Sampling and Converting a Waveform to PCM(Pulse Code Modulation)

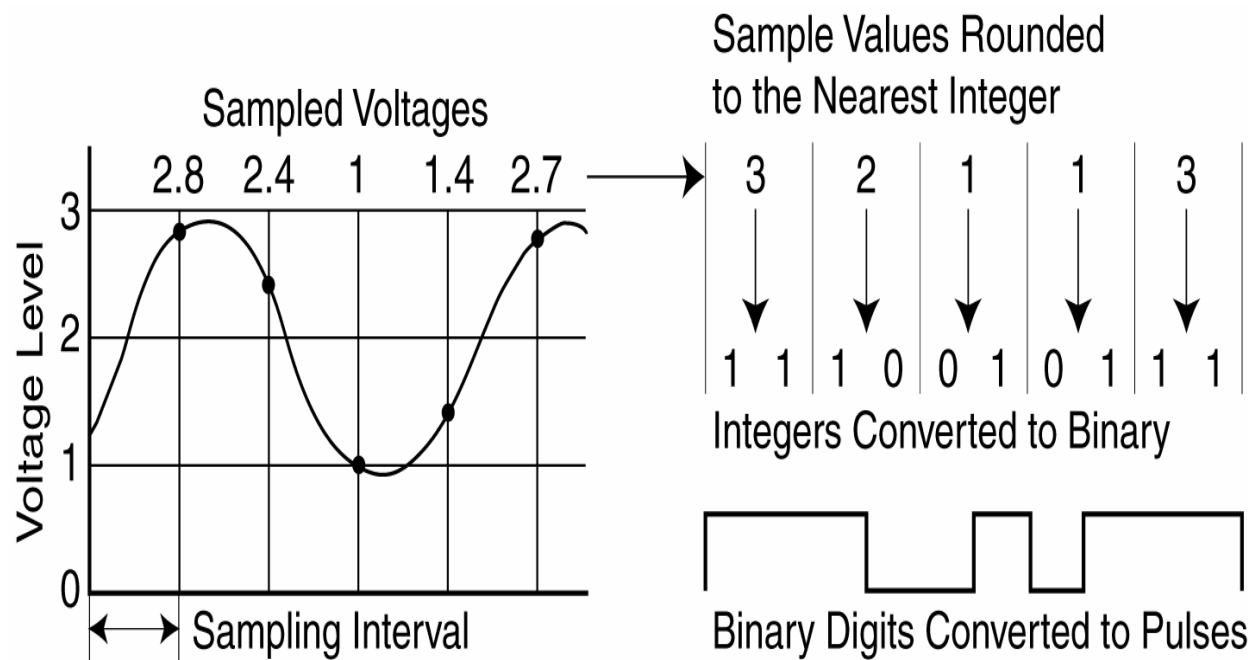

Sound Measurement

SPL (sound pressure level)

$$L_p = 10 \log_{10} \left(\frac{p_{rms}^2}{p_0^2} \right) = 20 \log_{10} \left(\frac{p_{rms}}{p_0} \right) dB$$

where P_0 is the reference sound pressure, P_{rms} is the RMS (Root Mean Square) sound pressure being measured.

$p_0 = 20 \mu Pa$ (rms) (air)

Digital Sound Format

- PCM (Pulse Code Modulation)
- DPCM (Differential Pulse Code Modulation)
- ADPCM (Adaptive Differential Pulse Code Modulation)
- MPEG (Moving Picture Experts Group)

Review of MV Techniques

- ❖ Main purpose: consider several related random variables simultaneously, equally important.
- ❖ MV methods, PCA, factor analysis, discriminate function analysis, cluster analysis, multidimensional scaling, etc...
 - Reduce variables numbers by the linear combinations of original variables.
 - PCA, a means of simplifying data by reducing the number of variables, has been successfully used.

Cold Modelling Rig (initial one)

Hight: 900 mm
Diameter: 290 mm



Cold Modelling Rig (new one)

Height: 500 mm
Diameter: 420 mm
Accelerometer:
B&K Type 4371

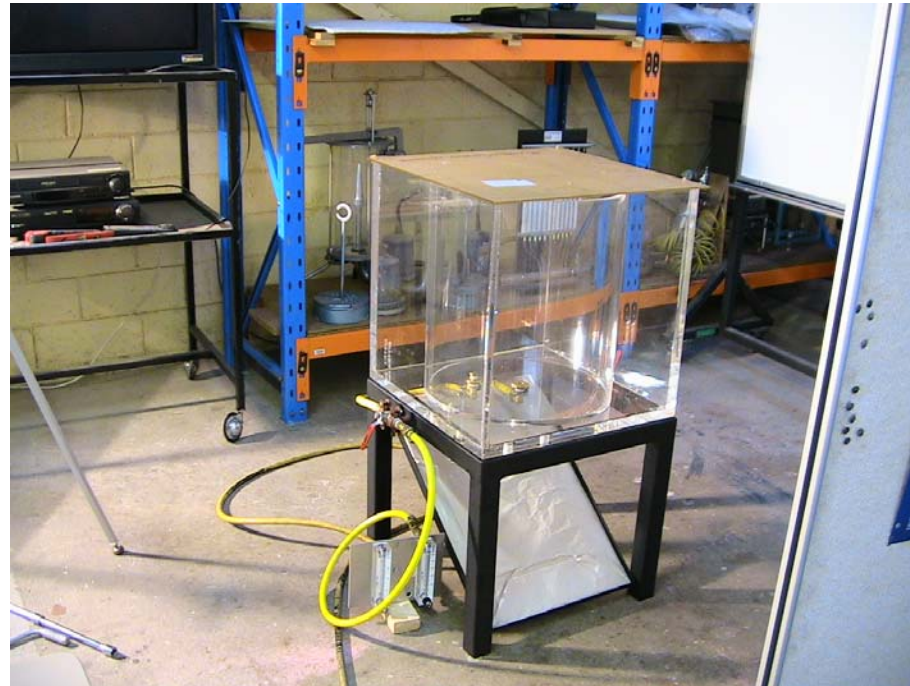

Bubble Experiment

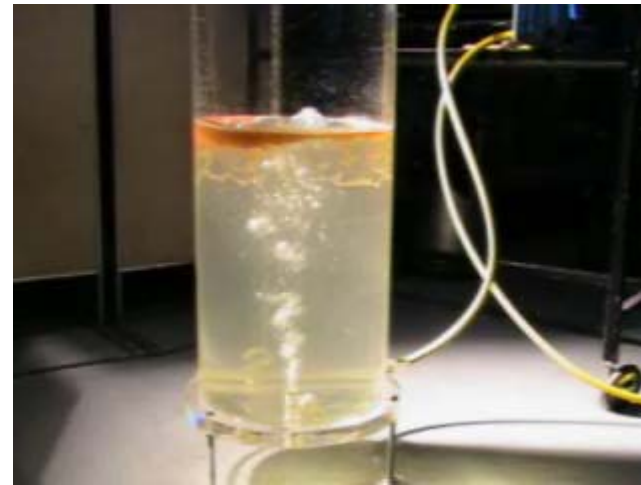
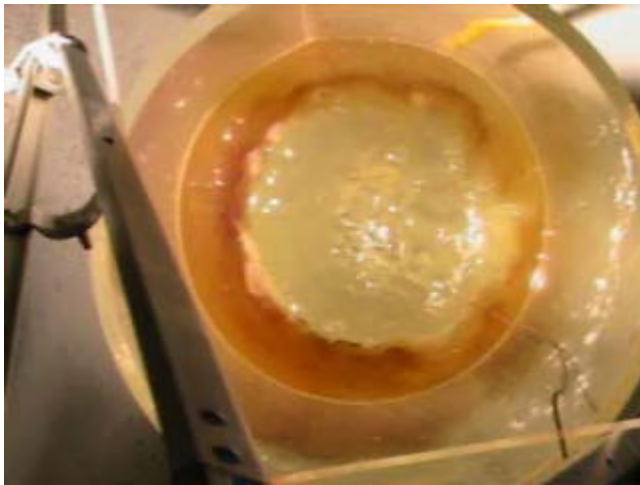

Bubble “eye” Image Treatment

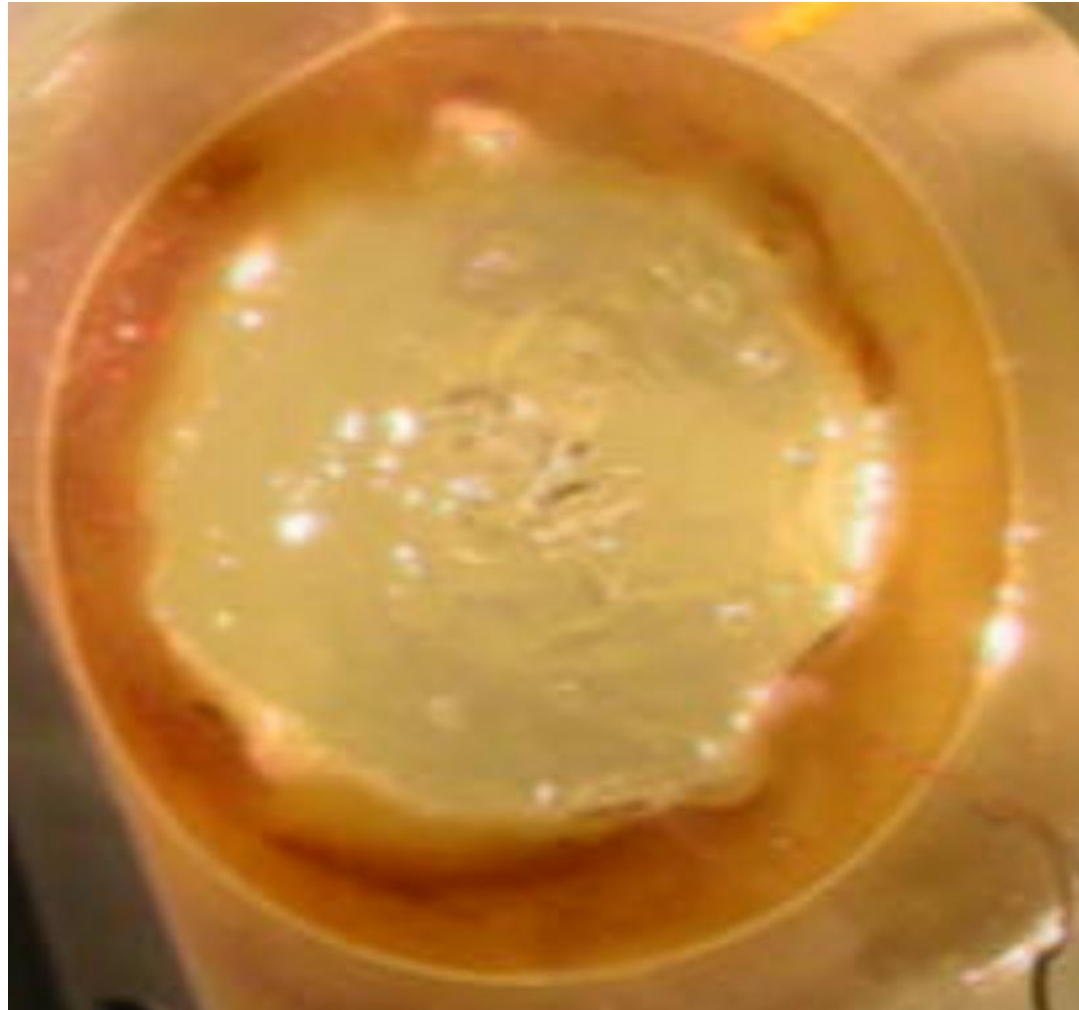

Digitalized with Scilab

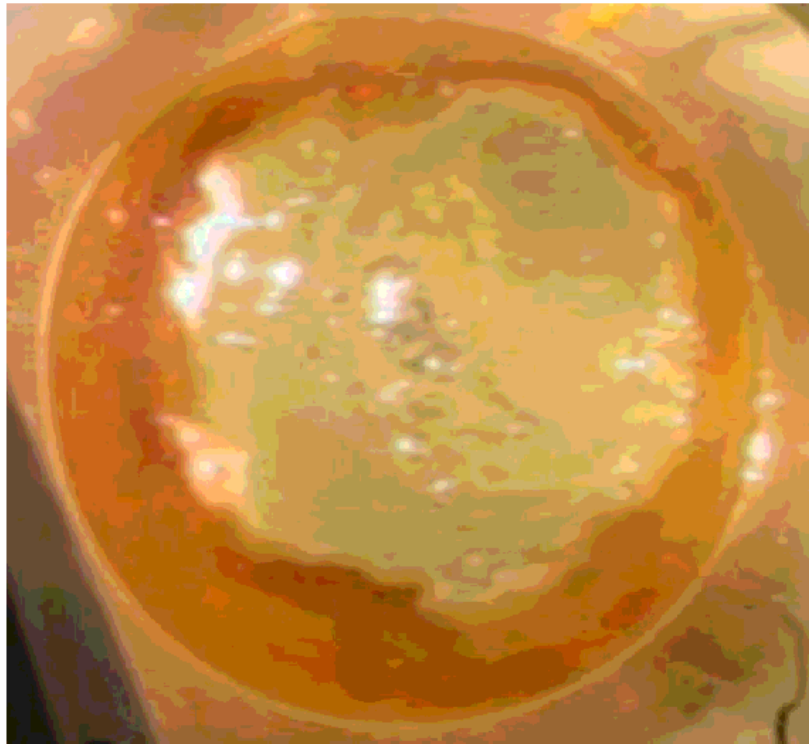

Numerical Description of the Image

```
t=imread("eye2.jpg")
```

```
Size: 755 rows X 830 columns
```

```
Truecolor Image,
```

```
t =(:, :, 1)
```

```
0.8627451 0.8627451 0.8627451 0.8627451 0.8627451 0.8627451 0.8627451 0.8627451
0.8666667 0.8666667 0.8627451 0.8627451 0.8627451 0.8627451 0.8627451 0.8627451
0.8627451 0.8627451 0.8666667 0.8666667 0.8627451 0.8627451 0.8627451 0.8627451
0.8627451 0.8627451 0.8627451 0.8627451 0.8666667 0.8666667
0.8627451 0.8627451 0.8627451 0.8627451 0.8627451 0.8627451 0.8627451 0.8627451
0.8666667 0.8666667 0.8588235 0.8588235 0.8588235 0.8588235 0.8588235 0.8588235
0.8588235 0.8588235 0.8627451 0.8627451 0.8588235 0.8588235 0.8588235 0.8588235
0.8588235 0.8588235 0.8588235 0.8588235 0.8627451 0.8627451
0.8588235 0.8588235 0.8588235 0.8588235 0.8588235 0.8588235 0.8588235 0.8588235
0.8627451 0.8627451 0.8588235 0.8588235 0.8588235 0.8588235 0.8588235 0.8588235
0.8588235 0.8588235 0.8627451 0.8627451 0.8392157 0.8392157 0.8392157 0.8431373
0.8431373 0.8470588 0.8470588 0.8470588 0.8470588 0.8470588
0.8392157 0.8392157 0.8392157 0.8431373 0.8431373 0.8470588 0.8470588 0.8470588
0.8470588 0.8470588 0.8392157 0.8392157 0.8392157 0.8431373 0.8431373 0.8470588
0.8470588 0.8470588
```

.....

The matrix has $755 \times 830 \times 3 = 1,879,950$ elements

PCA Analysis on Image

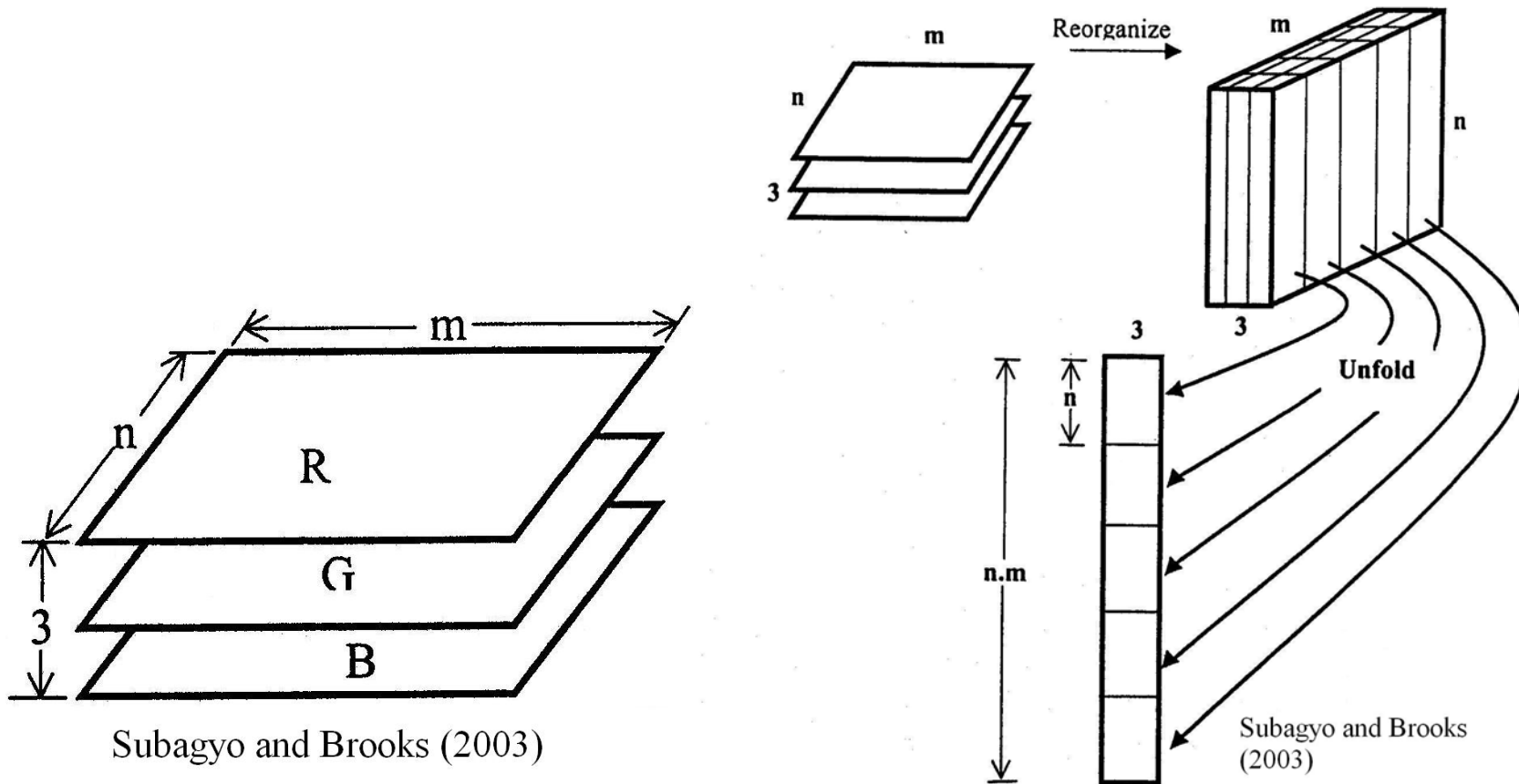

Acoustic Treatment

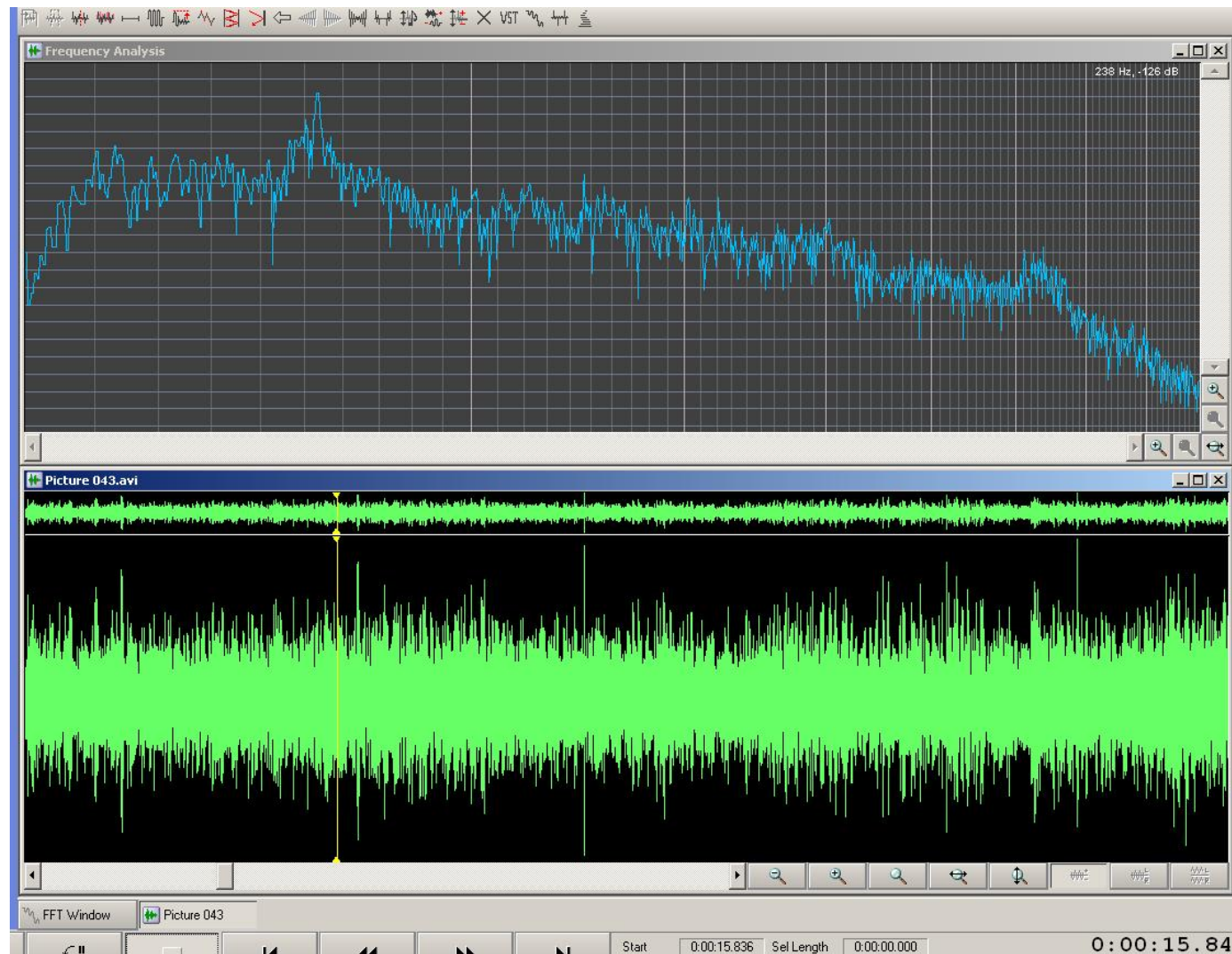

Numerical Description of the Acoustic Signal

`[y,Fs,bits]=auread('t2.au') , ('t2.au', 04 second signal)`

`y, 1 by 69696(size) 557584(bits)`

`Fs, frequency sampling, 16kHz`

`Bits, 16`

`Y=... column 318 to 326`

0.0000305	0.0000307	0.0000300	0.0002301	0.0016005
0.0001201	0.0043220	0.0111203	0.0002137	

`column 327 to 338`

0.0110203	0.0032334	0.0002305	0.0012305	0.0130301
0.0002334	0.0123205		

Industrial Trial

Initial trial (February 7th, 2008)

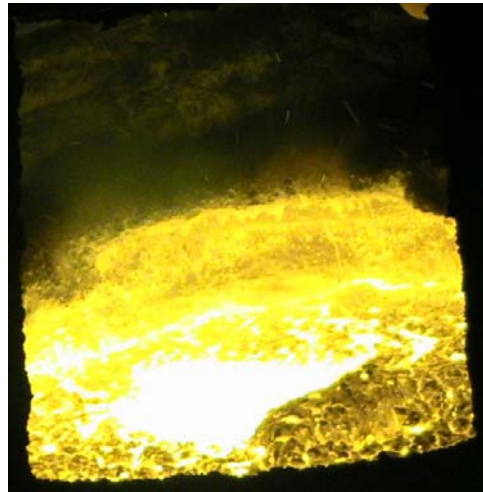

Figure 2a, Original Image

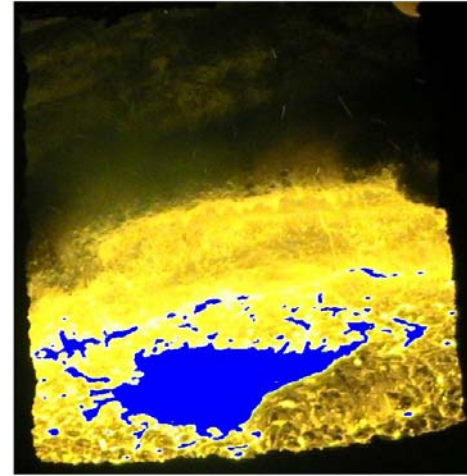

Figure 2b, Post Treated Image

- Taken at 32 Minutes in Stirring (7/2/08 13:38)
- Eye area: 7.04% of image area approximately 0.35 m²
- Argon flow rate: 45 Nm³/hr, slag height (est.) 74mm, Temperature: 1608° C
- Metal: N: 0.05735, S: 0.025, Al: 0.009, C: 0.12, Mn: 0.74, Si: 0.21

Presentations, Paper and Report

- (1) "Bubble Analysis" Wollongong University, (Jul 19, 2007)
- (2) "Progress Report" CSIRO Minerals, (Aug 30, 2007)
- (3) "Report on Industrial Trials" Industrial partner, (Apr 2, 2008)
- (4) "Ladle Eye Models", HTP Group meeting, (Apr 15, 2008)

"Ladle Eye phenomena" for Chemeca 2008 conference
(May 16, 2008)

"Report on Industrial Trials on Ladle Eye Measurements" (May 1,
2008)

3. Plan for the Next Stage

- (1) Commission the cold model (May-June)
- (2) Setup for combined digital image and acoustic analysis with multivariate statistical method (Jun-December)
- (3) Further industrial trial (June-July)
- (4) Transfer of analysis techniques to CSIRO AI model (Dec-Mar,2009)

**Great thanks for your
Attention
Suggestions !**